

HM-9A/9B

Microphone Holder

Description

The HM-9A/9B microphone holder with high strength and elastic material employed is designed for holding the microphone with slightly tapered or taperless body.

Features



With plastic screw 5/8"x27T(Female) in **HM-9A**



Polypropylene material employed, high elasticity durability in using



Copper screw 5/8"x27T(Female) inserted in **HM-9B**

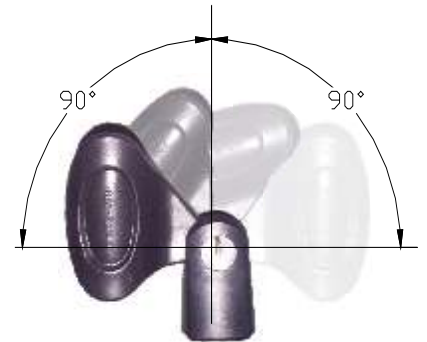

Operating free with a angle of 180°



Wide operating extent, 20~ 35mm diameter holdable



Transparent sealing hangable packaged easy exhibited and stocked