

Superlux®

HDB671

**COMPOSITE MATERIAL
WIRELESS BT HEADPHONE**

Contact

Marketing and sales

Superlux Taiwan
+886-2-26931323
sales@superlux.com.tw
support@superlux.com.tw

Manufacturing & logistics

Superlux Enterprise
Development (Shanghai) Co., Ltd.

HDB671

COMPOSITE MATERIAL WIRELESS BT HEADPHONE



GENERAL DESCRIPTION

HDB671 is the latest BT circumaural headphone of Superlux which is simple and styling. What even better is that, the 40mm dynamic drivers of HDB671 deliver the nearly perfect balance between the variety of the musical instruments and clarity. Furnished with the soft composite material earpads, HDB671 delivers the ultimate comfort, great and the surprising isolation. HDB671 presents every music details in a limitless flow.

FEATURES

- Extra long battery life 17-19 hours
- The soft composite material earpads provide incredible isolation and ultimate comfort
- New developed 40mm driver
- Much tighter bass, purer vocals. Spaciousness, balance, clarity carried through among ranges
- Furnished with headphone cable

SPECIFICATIONS

*Note: Specifications are subject to change.

Type	Dynamic, closed-back
Driver	Ø40mm, neodymium
Sensitivity	95dB SPL (1mW) at 1KHz
Frequency Response	20 – 20,000 Hz
Headphone Caliper Pressure	Approx. 3.5N
Rated Impedance	32Ω(copper-coated aluminum wire)
Cable	0.5 meter
Operating Distance	10m (free space)
Wireless BT VERSION	Version 4.1
Support	HFP v1.6/ HSPv1.2 / A2DP v1.2 / AVRCP v1.4
Battery	Talk time: up to 16 hrs Music playtime: up to 12 hrs Charging time: Around 2 hrs
WATERPROOF	IP4
Net Weight	238.5g
Dimensions (HxWxD)	205*175*100 (mm)
What's In The Box	Micro-USB cable / Connection Cable / Carrying Pouch

INSTRUCTIONS

• Powering on/off

ON Keep press the “Power Button” for around 5 seconds, blue light remains bright, the headset enters to pairing mode

OFF Keep press the “Power Button” for around 5 seconds, red light switch off

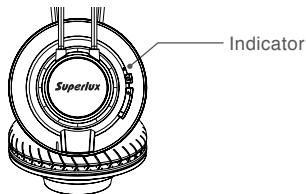

Indicator activity	System state
Blinking blue/red	Ready to pair
Blinking blue	Connected
Blinking Red	Need to charge

• To pair your headset with your mobile phone

1. Keep distance of the headset and mobile phone within 1 meter, the closer, the better.
2. Switch on the headset, ensure the headset entered to pairing mode, the LED indicator light blinking blue/red.
3. Switch on BT search function in your mobile phone or other device needs to be connected, the mobile phone will display the BT model "Superlux HDB671".
4. Select BT model "Superlux HDB671" (some mobile phone need to enter the password "0000" or "1111" to pair the headset), your headset will automatically connect with your mobile phone, blue light blinks.

***IMPORTANTY:** Generally, pairing time of headset has limited to 150 seconds, if the blue light has been off or blinks, means headset pairing mode has stopped. If pairing remains unsuccessful, please retry step 1 to 4 again.

• Disconnect the headset from the mobile

Switch off the headset; or switch off the BT function of your mobile.

• Reconnect the paired headset with the mobile phone

1. Keep distance of the headset and mobile phone within 1 meter.
2. Keep press the “Power Button” until the blue light blinks, the headset will automatically reconnect with your mobile phone.

• Charging

1. Before charging, make sure the power has been switched off.
2. Plug USB cable into the charging jack of headset; plug other side of USB charging cable into the USB charger or other charging device. Charging will start and the red light remains bright on the headset.
3. The headset takes approximately 2 hours for fully charged, blue light remains bright or red light switch off after charging completed.

• Checking the battery

1. While the headphones are in use, the battery indicator blinks red when the battery needs charging.
2. If you are connected to an Apple device, the device displays the head-phone battery charge level near the upper right corner of the screen.

• Media playback and volume functions

Function	What to do
Play/Pause	Press “Power Button” (⏻)
Skip Forward	Keep press “+” around 2 seconds
Skip Backward	Keep press “-” around 2 seconds
Volume Up	press “+”
Volume Down	press “-”

• Call functions

Function	What to do
Answer a call	Press “ Power Button ” (⏻)
End a call	Press “ Power Button ” (⏻)
Decline an incoming call	Keep press “ Power Button ” around 2 seconds (⏻)
Last call redialing	Double press “ Power Button ” (⏻)

Unit:mm/inch

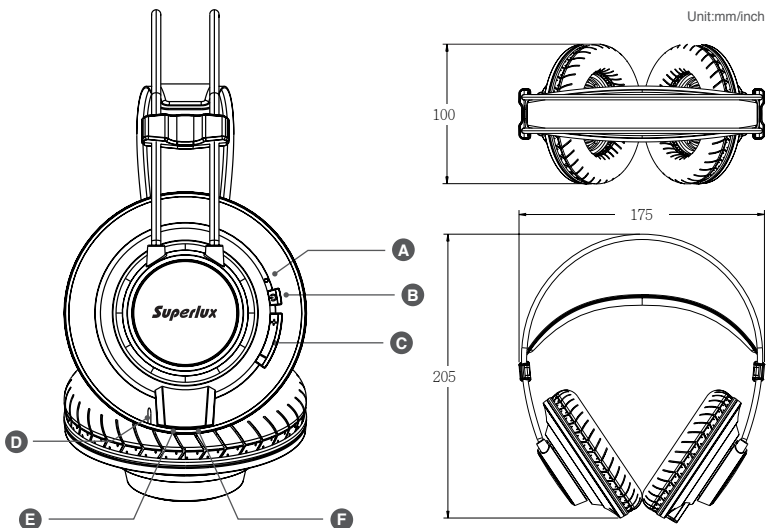

LAYOUT

- A** LED indicating light
- B** Power button
- C** Volume Up and Volume Down
- D** Microphone
- E** Headphone out connector (3.5mm)
- F** USB connector

SAFETY PRECAUTIONS

Safety symbols-“WARNING” AND “CAUTION”- and messages described below are used in this manual to prevent bodily injury and property damage which could result from mishandling. Before operating your product, read this manual first and understand the safety symbols and messages so you are thoroughly aware of the potential safety hazards.



WARNING: Indicates a potentially hazardous situation which, if mishandled, could result in death or serious personal injury.



CAUTION: Indicates a potentially hazardous situation which, if mishandled, could result in moderate or minor personal injury, and/or property damage.

WARNING



- Do not expose the unit to rain or an environment where it may be splashed by water or other liquids, as doing so may result in fire or electric shock.
- Do not attempt to modify this product. Doing so could result in personal injury and/or product failure.

CAUTION



- Do not subject to extreme force and do not pull on the cable or failures may result.
- Keep the device dry and avoid exposure to extreme temperatures and humidity.



LIMITED WARRANTY

Superlux Enterprise warrants all materials and workmanship under use as instructed by the user's manual of this product for a period of one year from the original date of purchase. Warranty period might be different by each area. Please contact your local dealer for more information. If any defects are found in the materials or workmanship or if the product fails to function properly during the applicable warranty period, Superlux Enterprise, at its option, will repair or replace the product. This warranty applies only to equipment sold and delivered by Superlux Enterprise's authorized distributors or dealers. However, the following are not covered: Damage caused by accident, misuse, abuse, product modification or neglect; damage occurring during shipment; damage resulting from failure to follow instructions contained in your Instruction manual; damage resulting from the performance of repairs by someone not authorized by Superlux; claims based upon any misrepresentations by the seller; any Superlux product on which the serial number has been defaced, modified or removed. Service and repairs of Superlux products are to be performed only at a factory-authorized facility or authorized distributors or dealers. Unauthorized service, repairs, or modification will void this warranty. To obtain repairs under warranty, you must have a copy of your sales receipt from the authorized Superlux dealer where you purchased the product. It is necessary to establish purchase date and determine whether your Superlux product is within the warranty period. To obtain factory authorized service, please contact authorized distributors, dealers or mail to support@superlux.com.tw.

THIS DEVICE COMPLIES WITH PART 15 OF THE FCC RULES CLASS B. OPERATION IS SUBJECT TO THE FOLLOWING TWO CONDITIONS:

- (1) THIS DEVICE MUST NOT CAUSE HARMFUL INTERFERENCE, AND
- (2) THIS DEVICE MUST ACCEPT ANY INTERFERENCE RECEIVED INCLUDING INTERFERENCE THAT MAY CAUSE UNDESIRED OPERATION. SUITABLE FOR HOME OR OFFICE USE.