



PRO238MKII

Large Diaphragm True Condenser Microphone

User Guide



Specifications

Type Condenser microphone	Low frequency roll-off 100 Hz, 12dB/OCT
Polar pattern Unidirectional (Cardioid), rotationally symmetrical about microphone axis, uniform with frequency. (Figure 1)	Power supply 9 to 52 VDC phantom
Frequency response 20 to 20,000 Hz (Figure 2)	Current consumption <3.5mA
Sensitivity (at 1,000 Hz Open Circuit Voltage) -40dBV/Pa (10mV/Pa) 3dB 1Pa=94dB SPL	Polarity Pin 2 output positive voltage (related to pin 3) when diaphragm receives positive pressure. (Diaphragm moving inward)
Rated impedance 200Ω	Connector Integral 3 pin male XLR type
Minimum load impedance 1,000Ω	Finish Metal construction with Grey painted finish
Equivalent noise level (A-weighted) 16dB (IEC/DIN 651)	Environmental conditions The PRO238MKII operates between -10 to +50 (14 to 122) with relative humidity between 0 to 95%.
Max. SPL (1 kΩ load) 136dB SPL (THD ≤1% 1kHz)	Dimensions φ 49.5mm(1.95in.) X 183.0mm (7.20in.) (Figure 3)
Dynamic range (1 kΩ Load) 120 dB	Net weight 350.0 grams (13.78oz.)
noise ratio-to- signal 78 dB	

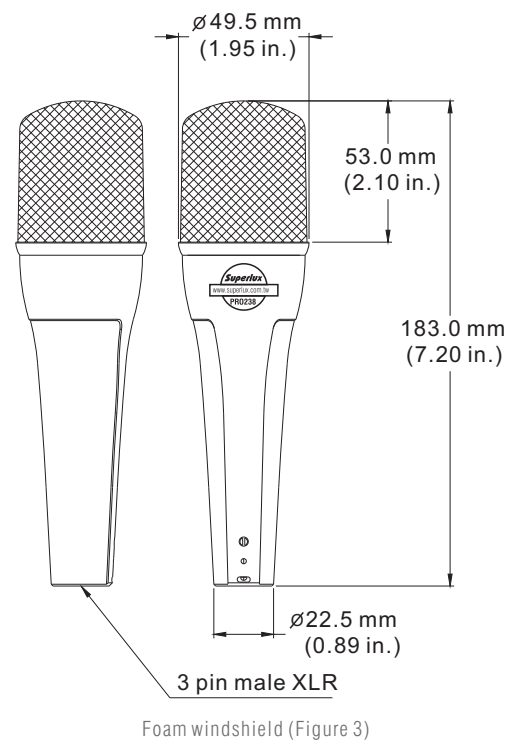
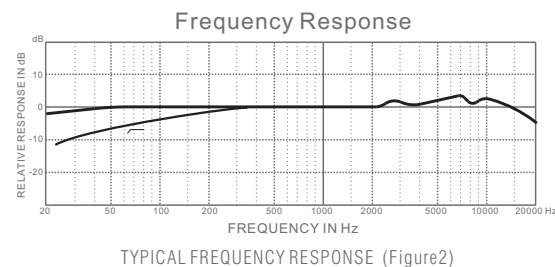
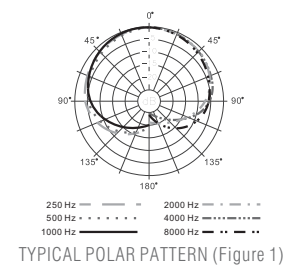

Description

PRO238MKII handheld large diaphragm condenser microphone is based on the superior performance, and improving the frequency response, lower handling noise, and mechanical structure. Modular design makes it easy to remove/restore the capsule. While the hidden low cut filter switch inside the chamber can be protected from mis-operation, and let the artist perform comfortably with the great holding feeling of the PRO238MKII.

Wide and extended frequency and optimized damping, this cardioids PRO238MKII exhibit nature and lively sound. A best microphone for live sound, broadcasting, and recording.

Features

- 1" gold plated 3 μm thin film diaphragm. Protected capsule.
- Wide range with mid-high band emphasis tailor frequency response.
- High dynamic range, low distortion.
- Superior modular design, lower handling noise.
- Hidden low cut filter.
- Warm and detail sound even at close-up.



Supplied accessories

- Foam windshield ----- S58
- Microphone holder ----- HM38S
- 5/8" to 3/8" adapter ----- YA1



Related accessories

Shock mount -----	HM26B
Phantom power supplier -----	PS2A
HM18AG Pop screen -----	HM18AG
Adjustable boom stand -----	MS131E

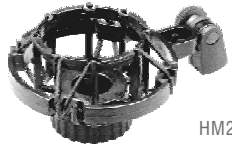

HM26B
Shock Mount



PS2A
Phantom
power supplier

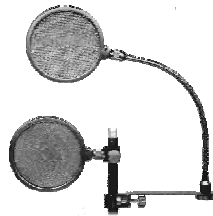

HM18AG
Pop screen

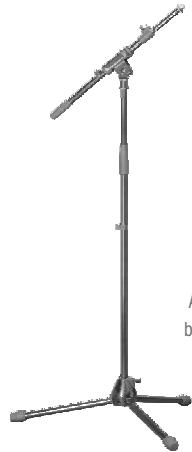

MS131E
Adjustable
boom stand

Knowing your microphone

Superlux provides variety selection of microphones for professionals and amateurs. To know your microphone is the first step to successful result.

Type of transducer



Condenser

Extremely light weight diaphragm, very sensitive to sound. Very small versions available for hiding applications. High performance condenser microphones are regarded as standard equipment of recording studios for extreme detail capturing. Operates with power, such as phantom or battery.

Powering microphone

Condenser microphones work with power. Professional standard is 48VDC phantom power. Some microphones work with lower voltage as low as 1.5VDC, such as battery power model. PRO238MKII work with 9 to 52VDC phantom only. Please make sure your sound system provide adequate power to the microphone.

About Frequency Response

Flat

Suitable for working at controlled environment, or for acoustic measurements. Although people pursuit flatness, but for non-professionals, it is a challenge to makes it works as expectation.

Popular curve response

Based on years of practical experience of pro users. There are curves to be build for various applications, so that it is very simple to use the microphone for the purpose. Limiting bandwidth, and emphasizing are typical skill.

Variable response

Incorporating switchable filters to eliminates interference, such as sub-sonic filter to cut air-conditioner and floor vibrations. And allows full flat when used in controlled environment.

Directivity



Cardioid

Picks up most signal on axis. Rejects side and picks up least to the back. Suitable for live sound re-inforcement. Apparent proximity effect and most singer likes to take this bass boost advantages which is not good for speech.

Distance to source

Close miking or distant miking sound very differently. Vocal recording or live performance practice close miking mostly. Suitable proximity effect is one desired target, and lower feedback problem is another factor for live sound application.

While distant miking is common practice for recording, especially stereo pair recording with large group of performers, such as orchestra or choir.

Distant miking generally picks up less bass section with pressure gradient type of microphone (cardioid, figure-8, shotgun...) due to acoustic nature and lack of proximity effects.

Rich bass with distant miking can be recorded with pressure type of microphone (Omni), which performs the same frequency response with close or distant pick-up.

Mounting the microphone

Pressure gradient microphone is very sensitive to vibration. Suitable shock mount for high performance microphone is necessary for extreme low noise recording. Sturdy stand can set the microphone exactly at the sweet spot and keep it there. Choose heavy duty microphone stand for studio condenser microphone which weights much more than handle microphone.

Superlux provides wide range of microphone stands for various demands. Big Foot Willie is specially developed for large condenser microphones that able to support 2 large microphones with stereo bracket for single point stereo recording.

Extension foot on all the 'E' versions serve to mount heavy studio microphone in limit space live sound applications.

Maintainence

Condenser microphone shall be kept in low humidity environment for best sound performance. Store the condenser microphones in airconditioned room or dehumidifier to keep away form moisture. Clean air is another important factor. Keep away from smoking environment to avoid tar residuals.



GOANG-FANN CO.,LTD.
3F, No. 7, Alley 2, Lane 342, Fu-Der 1st Road
Hsichih, Taipei, Taiwan
Tel: 886-2-2693 1323
Fax: 886-2-2694 8990
E-mail: sales@superlux.com.tw
Http://www.superlux.com.tw