

## PS2B

### 12V/ 48V PHANTOM POWER



#### Description

Condenser microphones demands various power specification. 48V phantom is the most common spec., and some demands lower 18V only. PS-2B works with both 12V and 48V spec. with 2 × 9V batteries or suitable AC adapter. Plastic armor protects the unit when use at outdoor, also serve as stacking feet.

This Phantom power adapter has a nice mini shape with vibration decreasing design. It can be piled up in use. This makes it very convenient and reliable foe either indoor or outdoor use.



#### Battery compartment Screw lock battery compartment cover.

Remove the cover with screwdriver when changing batteries.



#### Supplied Accessories

2 × 9V ( 1604A )  
Batteries

#### Features

- Powered by two 9V batteries or 16VDC adapter (option)
- Supply power to 2 microphones simultaneously
- 3-position switch (12V / OFF / 48V):  
48V for microphones with working voltage between 24V- 48V; 12V for microphones with lower voltages
- Battery power is convenient for outdoor and portable use. Turn the unit off to save battery power
- Low-noise circuit design

#### Schematic

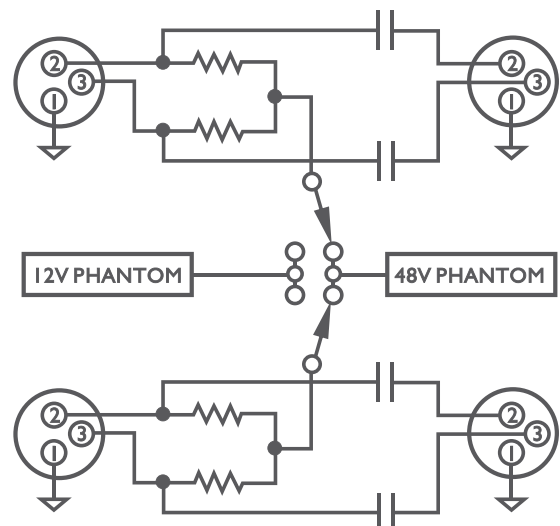

#### Specifications

Input connectors	2 × XLR ( female )
Out put connectors	2 × XLR ( male )
Power supply	2 × 9V ( 1604A ) batteries, External 16VDC powering ( $\geq 500\text{mA}$ )
Dimensions (with foot pads)	155 × 108 × 57 mm 6.1 × 4.3 × 2.2 inch
Weight (with batteries)	650g ( 22.9oz. )