

Superlux[®]

PS2B **PHANTOM POWER SUPPLY**

Contact

Marketing and sales

Goang-Fann Co., Ltd.
+886-2-26931323
sales@superlux.com.tw
support@superlux.com.tw

Manufacturing & logistics

Superlux Enterprise
Development (Shanghai) Co., Ltd.

PS2B

PHANTOM POWER SUPPLY

GENERAL DESCRIPTION

Condenser microphones demands various power specification. 48V phantom is the most common spec., and some demands lower 18V only. PS-2B works with both 12V and 48V spec. with 2 × 9V batteries or suitable AC adapter. Plastic armor protects the unit when use at outdoor, also serve as stacking feet. This Phantom power adapter has a nice mini shape with vibration decreasing design. It can be piled up in use. This makes it very convenient and reliable for either indoor or outdoor use.

FEATURES

- Powered by two 9V batteries or 16VDC adapter (option)
- Supply power to 2 microphones simultaneously
- 3-position switch (12V / OFF / 48V)

- 48V for microphones with working voltage between 24V-48V : 12V for microphones with lower voltages
- Battery power is convenient for outdoor and portable use. Turn the unit off to save battery power
- Low-noise circuit design

ACCESSORIES FURNISHED

9V (1604A) Batteries×2



Battery compartment Screw lock battery compartment cover. Remove the cover with screwdriver when changing batteries.

SPECIFICATIONS

*Note: Specifications are subject to change.

Input connectors	2×XLR (female)
Out put connectors	2×XLR (male)
Power supply	2×9V (1604A) batteries, External 16VDC powering (≥500mA)
Dimensions (with foot pads)	155×108×57 mm 6.1×4.3×2.2 inch
Weight (with batteries)	650g (22.9oz.)

SCHEMATIC

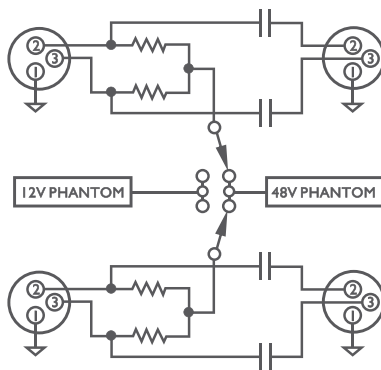

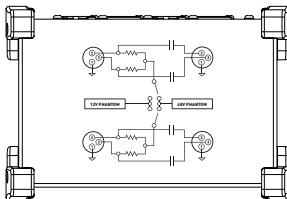
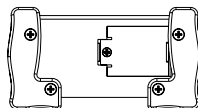
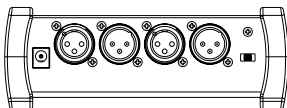
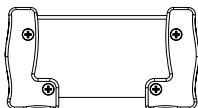
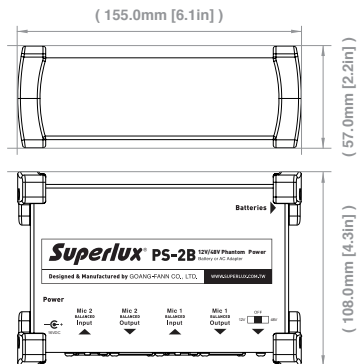

Unit:mm/inch

LIMITED WARRANTY

Superlux®

For compliance with the instructions which record in the user manual, Superlux Enterprise provide one year period warranty for all material and producing quality from purchase date. This warranty term will adjust according to different country or area. Please contact local distributor to receive more information. In the validity period, if there's any material, producing quality, or any function unavailable, Superlux will repair or replace the parts. This warranty is only for the product which selling by distributor or agent which authorized by Superlux. However, the situation below is excluded in the warranty :

The damage which caused by accident, abuse, improper instructions, self-modification and repair, or damage from transportation, not complying with the instructions which record in the manual, repair by the company which didn't authorized by Superlux Enterprise, request by distributor without authorized, or the serial number sticker on Superlux product is unidentified, modified, or removed. All repair of Superlux products can only accept from repair centre, distributor or agent which authorized by Superlux. Unauthorized repair, maintenance and modification will not receive relevant warranty and will be excluded in the warranty. Any repair guarantee under warranty need to provide selling receipt from authorized distributor or agent to make sure your Superlux product still in the warranty period. To obtain the original authorized repair warranty, please contact authorized distributor, agent or send an e-mail to support@superlux.com.tw to contact us.



WARNING! INDICATES A POTENTIALLY HAZARDOUS SITUATION WHICH IF MISHANDLED COULD RESULT IN DEATH OR SERIOUS PERSONAL INJURY OR PROPERTY DAMAGE.

- ※Do not expose the unit to rain or an environment where it may be splashed by water or other liquids as doing so may result in fire or electric shock.
- ※Do not attempt to modify this product. Doing so could result in personal injury and/or product failure.
- ※Do not subject to extreme force and do not pull on the cable, it might cause the product failures.
- ※Keep this product and the equipment which used together dry and avoid to exposure to extreme high temperature and humidity.